

5

4

3

2

1

D

C

B

A

D

C

B

A

REVISIONS				
ZONE	LTR	DESCRIPTION	DATE	APPROVED
	A	INITIAL RELEASE	4/8/96	
	B	REVISED TITLE	10/03/96	

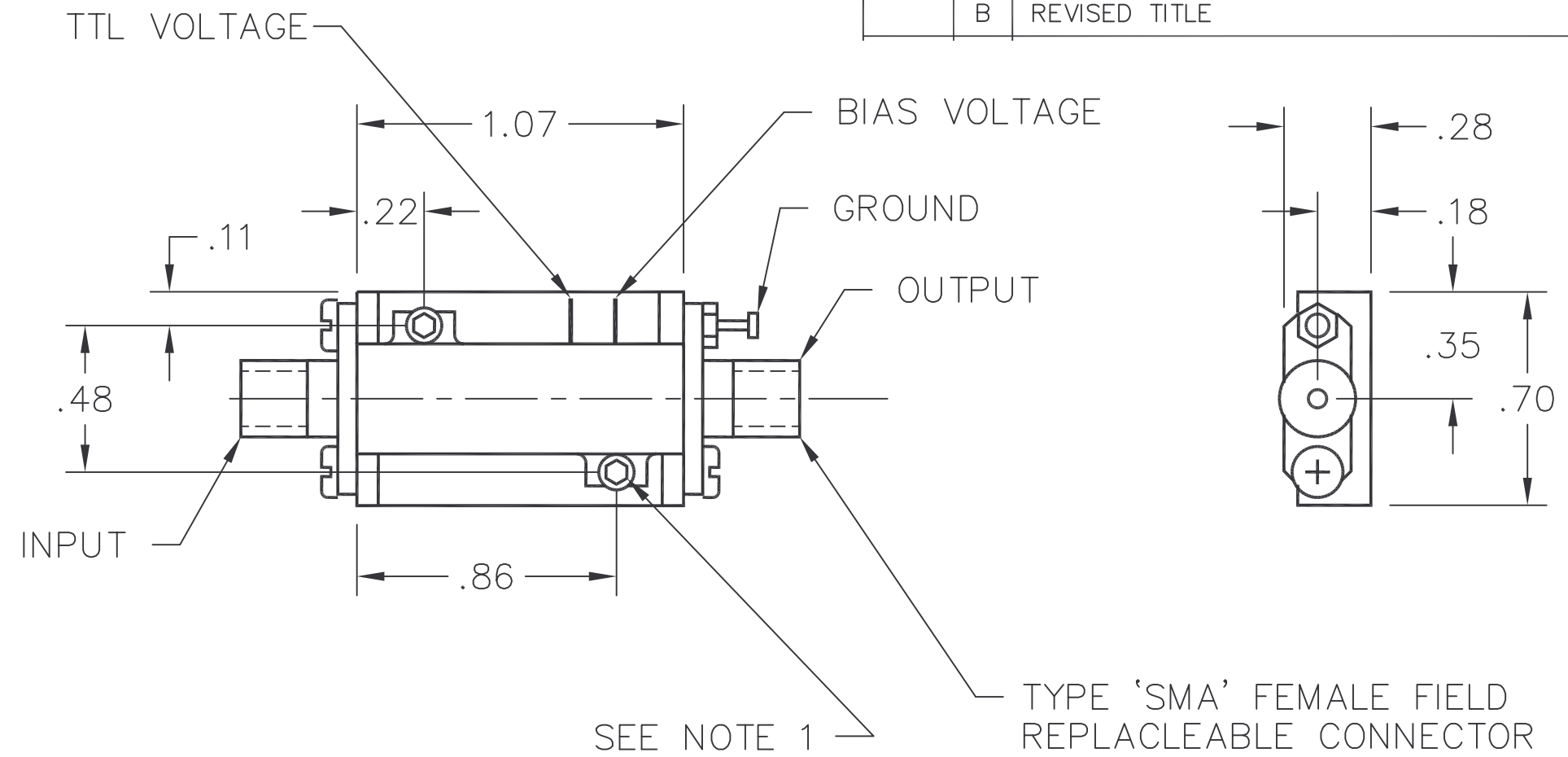

1. AMPLIFIER MAY BE READILY USED AS IS, BY REMOVING EXISTING 0-80 HARDWARE AND SUBSTITUTING SUPPLIED LONGER 0-80 SCREWS FOR CUSTOMER MOUNTING.

		UNLESS OTHERWISE SPECIFIED DIMENSIONS ARE IN INCHES TOLERANCES ON		DRN BY <i>C. Pinkham</i> DATE 4/8/96		 100 Davids Drive, Hauppauge, New York 11788			
		DECIMALS .XX±.01 ANGLES ±0°30'		CHKD BY				OUTLINE DRAWING AFSW/AFTL SERIES AMPLIFIER	
		MATERIAL		APPROVED BY		SIZE CODE IDENT. NO. REV. <b>B</b> 33592 127846 <b>B</b>			
		FINISH		PROJ ENGR					
NEXT ASSY USED ON		HEAT TREAT		ENG SECT					
APPLICATION				Q.A.					

5

4

3

2

1